

MTA

Denomination: **MTA ANCHOR**

Codes: **MTA**

Referencia: **FT MTA-en**

Date: **01/10/18**

Revision: **13**

Page: **1 of 12**



MTA

CHARACTERISTICS

- Roughness working principle; installation by controlled torque.
- Use for high loads.
- Valid for two installation depths.
- Easy installation.
- Use in non-cracked concrete.
- Previous installation, or through the fixture.
- Use for static or quasi-static loads.
- Zinc plated version.
- Variety of lengths and sizes, assembly flexibility.
- Available en INDEXcal

BASE MATERIAL



SIZE RANGE

M6 - M24

DRILL HOLE CONDITION



SECO

HUMEDO

INUNDADO

APPLICATION

- Structural applications in non-cracked concrete.
- Safety barriers.
- Billboards, machinery, boilers, signals, Steel beams, etc.
- Fixings wood structures in concrete.

MAXIMUM LOADS RECOMMENDED IN NON CRACKED CONCRETE [kg]

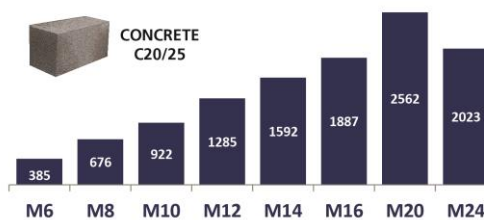

APPLICATION EXAMPLES

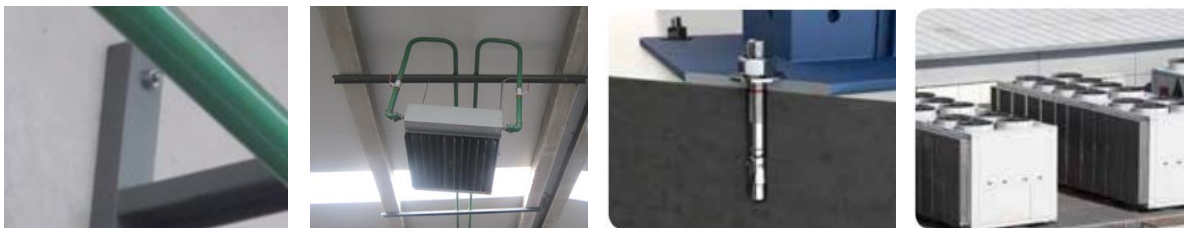

MTA

Denomination: **MTA ANCHOR**

Codes: **MTA**

Referencia: **FT MTA-en**

Date: **01/10/18**

Revision: **13**

Page: **2 of 12**

1. RANGE

ITEM	CODE	SIZE	PHOTO	COMPONENT	MATERIAL
1	AM	M6 a M24		Bolt Clip Nut Washer	Carbon steel cold formed, zinc-plated $\geq 5\mu\text{m}$ Carbon steel, zinc-plated $\geq 5\mu\text{m}$ DIN 934 class 6 ISO 898-1 zinc-plated $\geq 5\mu\text{m}$ DIN 125, DIN 9021 o DIN 440 zinc-plated $\geq 5\mu\text{m}$

2. ACCESSORIES

ITEM	CODE	PHOTO	DESCRIPTION
1	DOMTA		Accessory for anchor installation with hammer drill

3. INSTALLATION DATA

3.1. INSTALLATION DRAWING

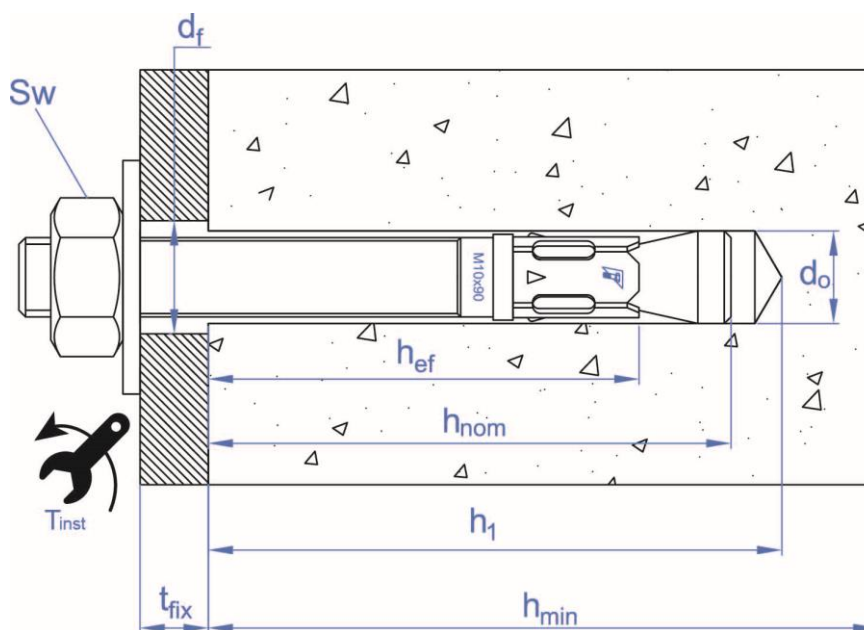

MTA

Denomination: **MTA ANCHOR**

Codes: **MTA**

Codes: **FT MTA-en**

Date: **01/10/18**

Revision: **13**

Page: **3 of 12**

3.2. INTALLATION PARAMETERS

General installation parameters								Standard installation depth								Reduced installation depth																			
Family	Code	Size	Drill bit diameter	Fixture clearance hole	Torque	Minimum allowable spacing	Minimum allowable edge distance	Minimum concrete thickness	Depth of drill hole \geq	Installation depth	Effective anchorage depth	Thickness of fixture \leq	Critical spacing (concrete cono)	Critical edge distance (concrete cone)	Critical spacing (splitting)	Critical edge distance (splitting)	Minimum concrete thickness	Depth of drill hole \geq	Installation depth	Effective anchorage depth	Thickness of fixture \leq	Critical spacing (concrete cono)	Critical edge distance (concrete cone)	Critical spacing (splitting)	Critical edge distance (splitting)										
[--]	[--]	[--]	d_o [mm]	d_f [mm]	T_{inst} [Nm]	S_{min} [mm]	C_{min} [mm]	h_{min} [mm]	h_1 [mm]	h_{nom} [mm]	h_{ef} [mm]	t_{fix} [mm]	$S_{cr,N}$ [mm]	$C_{cr,N}$ [mm]	$S_{cr,sp}$ [mm]	$C_{cr,sp}$ [mm]	h_{min} [mm]	h_1 [mm]	h_{nom} [mm]	h_{ef} [mm]	t_{fix} [mm]	$S_{cr,N}$ [mm]	$C_{cr,N}$ [mm]	$S_{cr,sp}$ [mm]	$C_{cr,sp}$ [mm]										
MTA	AM06045	M6 x 45	6	7	7	35	35	--	--	--	--	--	--	--	--	--	100	40	35	25	1	75	38	160	80										
	AM06055	M6 x 55						--	--	--	--	--	--	--	--	--	--	--	--	--	--	--	--	--	11	--	--	--	--						
	AM06060	M6 x 60						--	--	--	--	--	--	--	--	--	2	--	--	--	--	--	--	--	--	--	--	--	--	--					
	AM06065	M6 x 65						--	--	--	--	--	--	--	--	--	7	--	--	--	--	--	--	--	--	--	--	--	--	--					
	AM06070	M6 x 70						--	--	--	--	--	--	--	--	--	12	--	--	--	--	--	--	--	--	--	--	--	--	--					
	AM06080	M6 x 80						--	--	--	--	--	--	--	--	--	22	--	--	--	--	--	--	--	--	--	--	--	--	--	--				
	AM06085	M6 x 85						--	--	--	--	--	--	--	--	--	27	--	--	--	--	--	--	--	--	--	--	--	--	--	--				
	AM06090	M6 x 90						--	--	--	--	--	--	--	--	--	32	--	--	--	--	--	--	--	--	--	--	--	--	--	--	--			
	AM06100	M6 x 100						--	--	--	--	--	--	--	--	--	42	--	--	--	--	--	--	--	--	--	--	--	--	--	--	--			
	AM06110	M6 x 110						--	--	--	--	--	100	55	49,5	40	52	120	60	160	80	--	--	--	--	--	--	--	--	--	--				
	AM06120	M6 x 120						--	--	--	--	--	--	--	--	--	62	--	--	--	--	--	--	--	--	--	--	--	--	--	--	--			
	AM06130	M6 x 130						--	--	--	--	--	--	--	--	--	72	--	--	--	--	--	--	--	--	--	--	--	--	--	--	--			
	AM06140	M6 x 140						--	--	--	--	--	--	--	--	--	82	--	--	--	--	--	--	--	--	--	--	--	--	--	--	--			
	AM06150	M6 x 150						--	--	--	--	--	--	--	--	--	92	--	--	--	--	--	--	--	--	--	--	--	--	--	--	--			
	AM06160	M6 x 160						--	--	--	--	--	--	--	--	--	102	--	--	--	--	--	--	--	--	--	--	--	--	--	--	--			
	AM06170	M6 x 170						--	--	--	--	--	--	--	--	--	112	--	--	--	--	--	--	--	--	--	--	--	--	--	--	--			
	AM06180	M6 x 180						--	--	--	--	--	--	--	--	--	122	--	--	--	--	--	--	--	--	--	--	--	--	--	--	--			
	AM08050	M8 x 50						8	9	20	40	40	--	--	--	--	--	--	--	--	--	--	100	40	35	23	4	69	35	140	70				
	AM08060	M8 x 60											--	--	--	--	--	--	--	--	--	--	--	--	--	--	--	--	--	--	3	--	--	--	--
	AM08065	M8 x 65											--	--	--	--	--	--	--	--	--	--	--	--	--	--	--	--	--	--	8	--	--	--	--
	AM08075	M8 x 75											--	--	--	--	--	--	--	--	--	5	--	--	--	--	--	--	--	--	18	--	--	--	--
AM08090	M8 x 90	--	--	--	--	--	--						--	--	--	20	--	--	--	--	--	100	50	46,5	35	33	105	53	140	70					
AM08115	M8 x 115	--	--	--	--	--	100						65	59,5	48	45	144	72	192	96	--	--	--	--	43	--	--	--	--						
AM08120	M8 x 120	--	--	--	--	--	--						--	--	--	50	--	--	--	--	--	--	--	--	58	--	--	--	--	--					
AM08130	M8 x 130	--	--	--	--	--	--						--	--	--	60	--	--	--	--	--	--	--	--	63	--	--	--	--	--					
AM08155	M8 x 155	--	--	--	--	--	--						--	--	--	85	--	--	--	--	--	--	--	--	73	--	--	--	--	--					

MTA

Denomination: **MTA ANCHOR**

Codes: **MTA**

Reference: **FT MTA-en**

Date: **01/10/18**

Revision: **13**

Page: **6 of 12**

4. INSTALLATION PROCEDURE

4.1. CONCRETE INSTALLATION

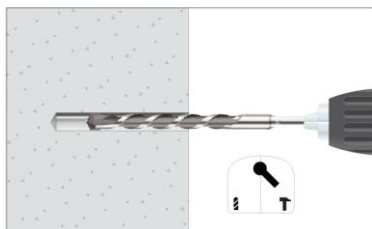

1. DRILLING

Check the concrete is well compacted and without significant porosity.
Suitable for dry, wet and flooded holes.
Use drill in hammer mode.
Drill according to specified depths in previous tables.



2. BLOW AND CLEAN

Clean the hole from dust and concrete remains.
Use blow pump and brush.

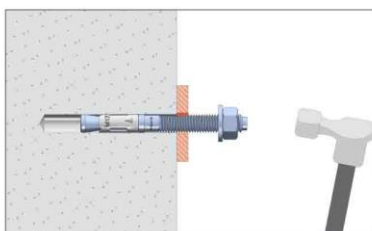

3. INSTALL

Insert the anchorage according to data specified in previous tables.
Use a hammer in case of need. DOMTA tool could be used alternatively.
Installation could be performed through the fixture or before setting the fixture.

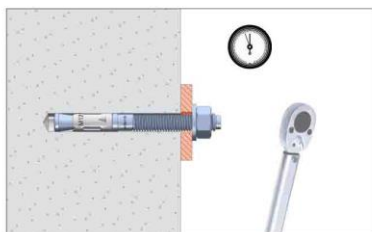

4. APPLY THE TORQUE

Apply the nominal torque specified in previous tables.
Use torque wrench in order to ensure correct installation.

MTA

Denomination: **MTA ANCHOR**

Codes: **MTA**

Reference: **FT MTA-en**

Date: **01/10/18**

Revision: **13**

Page: **7 of 12**

5. RESISTANCES

Resistances in concrete class C20/25 for an isolated anchor without spacing or concrete edge distance effects are indicated in the following table:

5.1 CHARACTERISTIC RESISTANCE [kN]

General Parameter			Standard installation depth		Reduced installation depth	
Family	Code	Size	Tension	Shear	Tension	Shear
			N_{Rk}	V_{Rk}	N_{Rk}	V_{Rk}
MTA	AM06045	M6 x 45	6,3	<u>5,1</u>	--	--
	AM06055	M6 x 55				
	AM06060	M6 x 60				
	AM06065	M6 x 65	7,4	<u>5,1</u>	--	--
	AM06070	M6 x 70				
	AM06080	M6 x 80				
	AM06085	M6 x 85				
	AM06090	M6 x 90				
	AM06100	M6 x 100				
	AM06110	M6 x 110				
	AM06120	M6 x 120				
	AM06130	M6 x 130				
	AM06140	M6 x 140				
	AM06150	M6 x 150	--	--	5,5	5,5
	AM06160	M6 x 160				
	AM06170	M6 x 170				
	AM06180	M6 x 180	--	--	10,0	10,4
	AM08050	M8 x 50				
	AM08060	M8 x 60				
	AM08065	M8 x 65	13,0	<u>9,3</u>	10,0	10,4
	AM08075	M8 x 75				
	AM08090	M8 x 90				
	AM08115	M8 x 115				
	AM08120	M8 x 120				
	AM08130	M8 x 130	--	--	12,7	12,7
	AM08155	M8 x 155				
	AM10065	M10 x 65				
	AM10070	M10 x 70	19,0	<u>14,7</u>	13,7	13,7
	AM10080	M10 x 80				
	AM10090	M10 x 90				
	AM10100	M10 x 100				
	AM10120	M10 x 120				
AM10140	M10 x 140					
AM10150	M10 x 150					
AM10160	M10 x 160					
AM10170	M10 x 170					
AM10210	M10 x 210	--				
AM10230	M10 x 230					
AM12075	M12 x 75					
AM12080	M12 x 80	--	--	17,8	17,8	
AM12090	M12 x 90					
AM12100	M12 x 100					
AM12110	M12 x 110	26,4	<u>20,6</u>	17,8	17,8	
AM12120	M12 x 120					
AM12140	M12 x 140					
AM12160	M12 x 160					
AM12180	M12 x 180					
AM12220	M12 x 220					
AM12250	M12 x 250					

MTA

Denomination: **MTA ANCHOR**

Codes: **MTA**

Reference: **FT MTA-en**

Date: **01/10/18**

Revision: **13**

Page: **8 of 12**

General Parameter			Standard installation depth		Reduced installation depth	
Family	Code	Size	Tension	Shear	Tension	Shear
			<i>N_{Rk}</i>	<i>V_{Rk}</i>	<i>N_{Rk}</i>	<i>V_{Rk}</i>
MTA	AM14080	M14 x 80	--	--	13,7	13,7
	AM14100	M14 x 100	--	--	24,6	<u>28,1</u>
	AM14120	M14 x 120	32,8	<u>28,1</u>	--	--
	AM14145	M14 x 145				
	AM14170	M14 x 170				
	AM14220	M14 x 220				
	AM14250	M14 x 250				
	AM16090	M16 x 90	--	--	17,3	17,3
	AM16110	M16 x 110	--	--	26,4	<u>38,4</u>
	AM16125	M16 x 125	38,8	<u>38,4</u>	26,4	<u>38,4</u>
	AM16145	M16 x 145				
	AM16170	M16 x 170				
	AM16220	M16 x 220				
	AM16250	M16 x 250				
	AM16280	M16 x 280	--	--	30,2	60,4
	AM20120	M20 x 120				
	AM20170	M20 x 170				
	AM20220	M20 x 220	52,7	<u>56,3</u>	32,8	65,6
AM20270	M20 x 270	50,0	<u>84,7</u>	--	--	
AM24180	M24 x 180					
AM24260	M24 x 260					

1 KN ≈ 100 kg

Values underlined and in italics show Steel failure, **bold** values concrete failure and other indicate pull out failure.

MTA

Denomination: **MTA ANCHOR**

Codes: **MTA**

Reference: **FT MTA-en**

Date: **01/10/18**

Revision: **13**

Page: **9 of 12**

5.2 DESIGN RESISTANCE [kN]

General Parameter			Standard installation depth		Reduced installation depth	
Family	Code	Size	Tension	Shear	Tension	Shear
			N_{Rd}	V_{Rd}	N_{Rd}	V_{Rd}
MTA	AM06045	M6 x 45	4,2	<u>4,0</u>	--	--
	AM06055	M6 x 55			--	--
	AM06060	M6 x 60	<u>5,2</u>	<u>4,0</u>	--	--
	AM06065	M6 x 65				
	AM06070	M6 x 70				
	AM06080	M6 x 80				
	AM06085	M6 x 85				
	AM06090	M6 x 90				
	AM06100	M6 x 100				
	AM06110	M6 x 110				
	AM06120	M6 x 120				
	AM06130	M6 x 130				
	AM06140	M6 x 140				
	AM06150	M6 x 150				
	AM06160	M6 x 160				
	AM06170	M6 x 170				
	AM06180	M6 x 180				
	AM08050	M8 x 50	--	--	3,7	3,7
	AM08060	M8 x 60	--	--	6,6	6,9
	AM08065	M8 x 65	<u>9,3</u>	<u>7,4</u>	6,6	6,9
	AM08075	M8 x 75				
	AM08090	M8 x 90				
	AM08115	M8 x 115				
	AM08120	M8 x 120				
	AM08130	M8 x 130				
	AM08155	M8 x 155				
	AM10065	M10 x 65	--	--	8,5	8,5
	AM10070	M10 x 70	--	--	9,1	9,1
	AM10080	M10 x 80	12,6	<u>11,7</u>	9,1	9,1
	AM10090	M10 x 90				
	AM10100	M10 x 100				
	AM10120	M10 x 120				
AM10140	M10 x 140					
AM10150	M10 x 150					
AM10160	M10 x 160					
AM10170	M10 x 170					
AM10210	M10 x 210					
AM10230	M10 x 230					
AM12075	M12 x 75	--	--	9,4	9,4	
AM12080	M12 x 80	--	--	11,9	11,9	
AM12090	M12 x 90	17,6	<u>16,4</u>	11,9	11,9	
AM12100	M12 x 100					
AM12110	M12 x 110					
AM12120	M12 x 120					
AM12140	M12 x 140					
AM12160	M12 x 160					
AM12180	M12 x 180					
AM12220	M12 x 220					
AM12250	M12 x 250					

MTA

Denomination: **MTA ANCHOR**

Codes: **MTA**

Reference: **FT MTA-en**

Date: **01/10/18**

Revision: **13**

Page: **10 of 12**

General Parameter			Standard installation depth		Reduced installation depth	
Family	Code	Size	Tension	Shear	Tension	Shear
			<i>N_{Rd}</i>	<i>V_{Rd}</i>	<i>N_{Rd}</i>	<i>V_{Rd}</i>
MTA	AM14080	M14 x 80	--	--	9,1	9,1
	AM14100	M14 x 100	--	--	16,4	<u>22,4</u>
	AM14120	M14 x 120	21,8	<u>22,4</u>	--	--
	AM14145	M14 x 145				
	AM14170	M14 x 170				
	AM14220	M14 x 220				
	AM14250	M14 x 250				
	AM16090	M16 x 90	--	--	11,5	11,5
	AM16110	M16 x 110	--	--	17,6	<u>30,7</u>
	AM16125	M16 x 125	25,9	<u>30,7</u>	17,6	<u>30,7</u>
	AM16145	M16 x 145				
	AM16170	M16 x 170				
	AM16220	M16 x 220				
	AM16250	M16 x 250				
	AM16280	M16 x 280	--	--	20,1	40,2
	AM20120	M20 x 120				
	AM20170	M20 x 170				
	AM20220	M20 x 220	35,1	<u>45,0</u>	21,8	43,7
AM20270	M20 x 270	27,7	<u>67,7</u>	--	--	
AM24180	M24 x 180					
AM24260	M24 x 260					

1 KN ≈ 100 kg

Values underlined and in italics show Steel failure, **bold** values concrete failure and other indicate pull out failure.

MTA

Denomination: **MTA ANCHOR**

Codes: **MTA**

Reference: **FT MTA-en**

Date: **01/10/18**

Revision: **13**

Page: **11 of 12**

5.3 MAXIMUM LOADS RECOMMENDED [kN] (con $\gamma_F=1.4$)

General Parameter			Standard installation depth		Reduced installation depth	
Family	Code	Size	Tension	Shear	Tension	Shear
			N_{rec}	V_{rec}	N_{rec}	V_{rec}
MTA	AM06045	M6 x 45	3,0	<u>2,9</u>	--	--
	AM06055	M6 x 55				
	AM06060	M6 x 60				
	AM06065	M6 x 65				
	AM06070	M6 x 70				
	AM06080	M6 x 80				
	AM06085	M6 x 85	<u>3,7</u>	<u>2,9</u>	--	--
	AM06090	M6 x 90				
	AM06100	M6 x 100				
	AM06110	M6 x 110				
	AM06120	M6 x 120				
	AM06130	M6 x 130				
	AM06140	M6 x 140				
	AM06150	M6 x 150				
	AM06160	M6 x 160				
	AM06170	M6 x 170				
	AM06180	M6 x 180	--	--	2,6	2,6
	AM08050	M8 x 50				
	AM08060	M8 x 60				
	AM08065	M8 x 65				
	AM08075	M8 x 75	<u>6,6</u>	<u>5,3</u>	4,7	4,9
	AM08090	M8 x 90				
	AM08115	M8 x 115				
	AM08120	M8 x 120				
	AM08130	M8 x 130				
	AM08155	M8 x 155				
	AM10065	M10 x 65	--	--	6,0	6,0
	AM10070	M10 x 70				
	AM10080	M10 x 80	9,0	<u>8,4</u>	6,5	6,5
	AM10090	M10 x 90				
	AM10100	M10 x 100				
	AM10120	M10 x 120				
AM10140	M10 x 140					
AM10150	M10 x 150					
AM10160	M10 x 160					
AM10170	M10 x 170					
AM10210	M10 x 210					
AM10230	M10 x 230	--				
AM12075	M12 x 75					
AM12080	M12 x 80	--	--	8,5	8,5	
AM12090	M12 x 90					
AM12100	M12 x 100	12,6	<u>11,7</u>	8,5	8,5	
AM12110	M12 x 110					
AM12120	M12 x 120					
AM12140	M12 x 140					
AM12160	M12 x 160					
AM12180	M12 x 180					
AM12220	M12 x 220					
AM12250	M12 x 250					

MTA

Denomination: **MTA ANCHOR**

Codes: **MTA**

Reference: **FT MTA-en**

Date: **01/10/18**

Revision: **13**

Page: **12 of 12**

General Parameter			Standard installation depth		Reduced installation depth	
Family	Code	Size	Tension	Shear	Tension	Shear
			N _{rec}	V _{rec}	N _{rec}	V _{rec}
MTA	AM14080	M14 x 80	--	--	6,5	6,5
	AM14100	M14 x 100	--	--	11,7	<u>16,0</u>
	AM14120	M14 x 120	15,6	<u>16,0</u>	--	--
	AM14145	M14 x 145				
	AM14170	M14 x 170				
	AM14220	M14 x 220				
	AM14250	M14 x 250				
	AM16090	M16 x 90	--	--	8,2	8,2
	AM16110	M16 x 110	--	--	12,6	<u>21,9</u>
	AM16125	M16 x 125	18,5	21,9	12,6	<u>21,9</u>
	AM16145	M16 x 145				
	AM16170	M16 x 170				
	AM16220	M16 x 220				
	AM16250	M16 x 250				
	AM16280	M16 x 280	--	--	14,3	28,7
	AM20120	M20 x 120				
	AM20170	M20 x 170				
	AM20220	M20 x 220	25,1	<u>32,1</u>	15,6	31,2
AM20270	M20 x 270	19,8	<u>48,4</u>	--	--	
AM24180	M24 x 180					
AM24260	M24 x 260					

1 KN ≈ 100 kg

Values underlined and in italics show Steel failure, **bold** values concrete failure and other indicate pull out failure.